

品番	サイズ	D	P	d	H	A	W	b	c	t
SU10340-0013	13SU	15.88	28	W3/8	46	23	25	53.5	7	1.5
SU10340-0020	20SU	22.22	34	W3/8	54	26	25	59.5	7	1.5
SU10340-0025	25SU	28.58	40	W3/8	60	26	25	66.5	7	1.5
SU10340-0030	30SU	34.0	46	W3/8	66	26	25	72.5	7	1.5
SU10340-0040	40SU	42.7	56	W3/8	75	25	25	83	7.5	1.5
SU10340-0050	50SU	48.7	62	W3/8	81	25	25	89	7.5	1.5
SU10340-0060	60SU	60.5	74	W3/8	93	25	25	101	7.5	1.5
SU10340-0075	75SU	76.3	88	W3/8	113	30	25	116	7.5	1.5
SU10340-0080	80SU	89.1	101	W3/8	126	30	25	129	8.5	1.5
SU10340-0100	100SU	114.3	126	W3/8	151	30	25	154	8.5	1.5
SU10340-0125	125SU	139.8	154	W1/2	187	40	30	190	9.8	1.8
SU10340-0150	150SU	165.2	182	W1/2	214	40	30	218	9.8	1.8
SU10340-0200	200SU	216.3	232	W1/2	264	40	30	268	9.8	1.8
SU10340-0250	250SU	267.4	286	W5/8	330	55	40	331	11	2.0
SU10340-0300	300SU	318.5	341	W5/8	391	65	40	386	11	2.0

品名 PRODUCT NAME SU管用 ELフラットUボルト		サイズ SIZE 13SU ~ 300SU	
品番 PARTS NO. SU10340-	被覆色 COLOR AWJブルー	表面処理 SURFACE TREATMENT 電気亜鉛メッキ	
材質 A MATERIAL A エラストマー (TPE)	材質 B MATERIAL B SS400	材質 C MATERIAL C エラストマー (TPE)	
承認 APPROVAL	検図 CHECK	担当 IN CHARGE A.Kaneshige	製図 DRAWN 21.02.15

**AWJ** AWJ株式会社

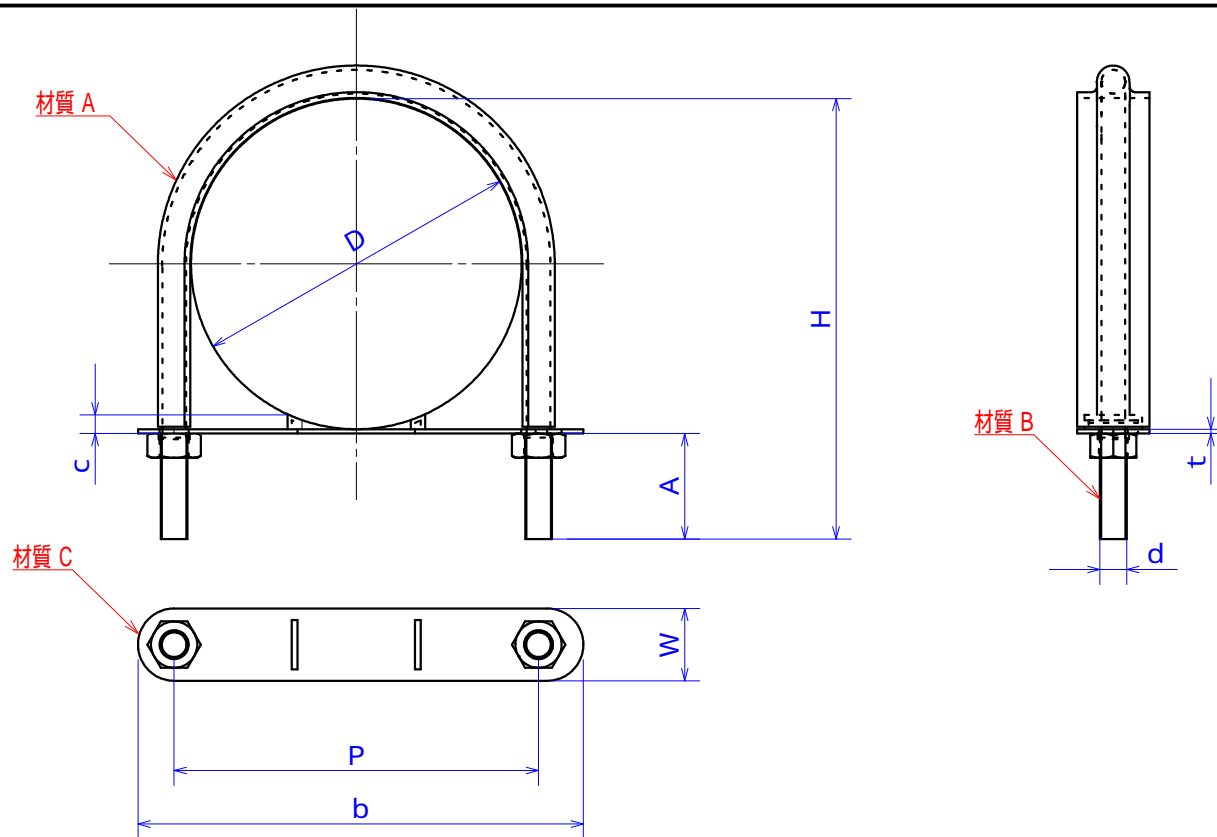

品番	サイズ	D	P	d	H	A	W	b	c	t
SU10342-0013	13SU	15.88	28	W3/8	46	23	25	53.5	7	1.5
SU10342-0020	20SU	22.22	34	W3/8	54	26	25	59.5	7	1.5
SU10342-0025	25SU	28.58	40	W3/8	60	26	25	66.5	7	1.5
SU10342-0030	30SU	34.0	46	W3/8	66	26	25	72.5	7	1.5
SU10342-0040	40SU	42.7	56	W3/8	75	25	25	83	7.5	1.5
SU10342-0050	50SU	48.7	62	W3/8	81	25	25	89	7.5	1.5
SU10342-0060	60SU	60.5	74	W3/8	93	25	25	101	7.5	1.5
SU10342-0075	75SU	76.3	88	W3/8	113	30	25	116	7.5	1.5
SU10342-0080	80SU	89.1	101	W3/8	126	30	25	129	8.5	1.5
SU10342-0100	100SU	114.3	126	W3/8	151	30	25	154	8.5	1.5
SU10342-0125	125SU	139.8	154	W1/2	187	40	30	190	9.8	1.8
SU10342-0150	150SU	165.2	182	W1/2	214	40	30	218	9.8	1.8
SU10342-0200	200SU	216.3	232	W1/2	264	40	30	268	9.8	1.8
SU10342-0250	250SU	267.4	286	W5/8	330	55	40	331	11	2.0
SU10342-0300	300SU	318.5	341	W5/8	391	65	40	386	11	2.0

品名 PRODUCT NAME		ステンレス SU管用 ELフラットUボルト		サイズ SIZE	13SU ~ 300SU
品番 PARTS NO.	SU10342-	被覆色 COLOR	AWJブルー	表面処理 SURFACE TREATMENT	脱脂処理
材質 A MATERIAL A	エラストマー (TPE)	材質 B MATERIAL B	SUS304	材質 C MATERIAL C	エラストマー (TPE)
承認 APPROVAL	検図 CHECK	担当 IN CHARGE	A.Kaneshige	製図 DRAWN	21.02.15

**AWJ AWJ株式会社**

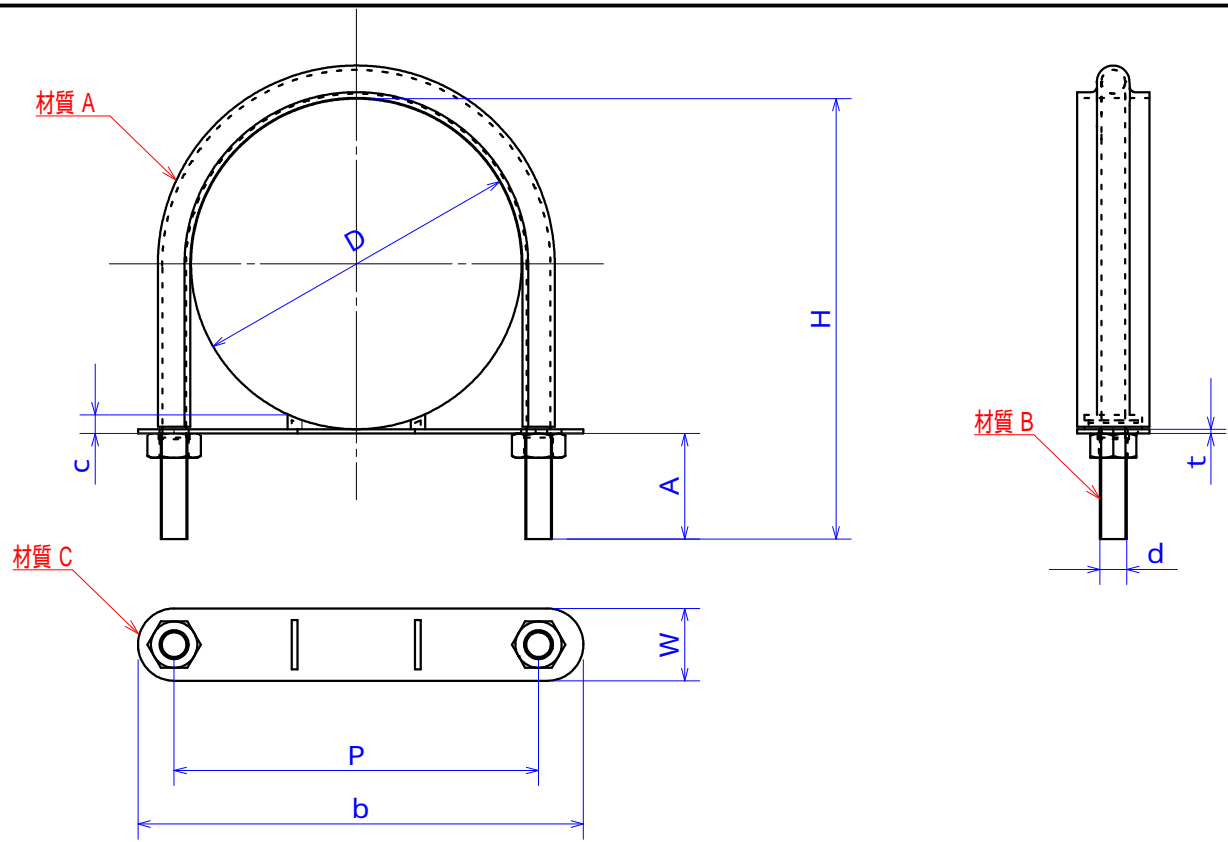

品番	サイズ	D	P	d	H	A	W	b	c	t
SU10358-0013	13SU	15.88	28	W3/8	46	23	25	53.5	7	1.5
SU10358-0020	20SU	22.22	34	W3/8	54	26	25	59.5	7	1.5
SU10358-0025	25SU	28.58	40	W3/8	60	26	25	66.5	7	1.5
SU10358-0030	30SU	34.0	46	W3/8	66	26	25	72.5	7	1.5
SU10358-0040	40SU	42.7	56	W3/8	75	25	25	83	7.5	1.5
SU10358-0050	50SU	48.7	62	W3/8	81	25	25	89	7.5	1.5
SU10358-0060	60SU	60.5	74	W3/8	93	25	25	101	7.5	1.5
SU10358-0075	75SU	76.3	88	W3/8	113	30	25	116	7.5	1.5
SU10358-0080	80SU	89.1	101	W3/8	126	30	25	129	8.5	1.5
SU10358-0100	100SU	114.3	126	W3/8	151	30	25	154	8.5	1.5
SU10358-0125	125SU	139.8	154	W1/2	187	40	30	190	9.8	1.8
SU10358-0150	150SU	165.2	182	W1/2	214	40	30	218	9.8	1.8
SU10358-0200	200SU	216.3	232	W1/2	264	40	30	268	9.8	1.8
SU10358-0250	250SU	267.4	286	W5/8	330	55	40	331	11	2.0
SU10358-0300	300SU	318.5	341	W5/8	391	65	40	386	11	2.0

品名 PRODUCT NAME ドブメッキ SU管用 ELフラットUボルト		サイズ SIZE 13SU ~ 300SU	
品番 PARTS NO. SU10358-	被覆色 COLOR ブラック	表面処理 SURFACE TREATMENT 溶融亜鉛メッキ	
材質 A MATERIAL A エラストマー (TPE)	材質 B MATERIAL B SS400	材質 C MATERIAL C エラストマー (TPE)	
承認 APPROVAL	検図 CHECK	担当 IN CHARGE A.Kaneshige	製図 DRAWN 21.02.15

**AWJ** AWJ株式会社

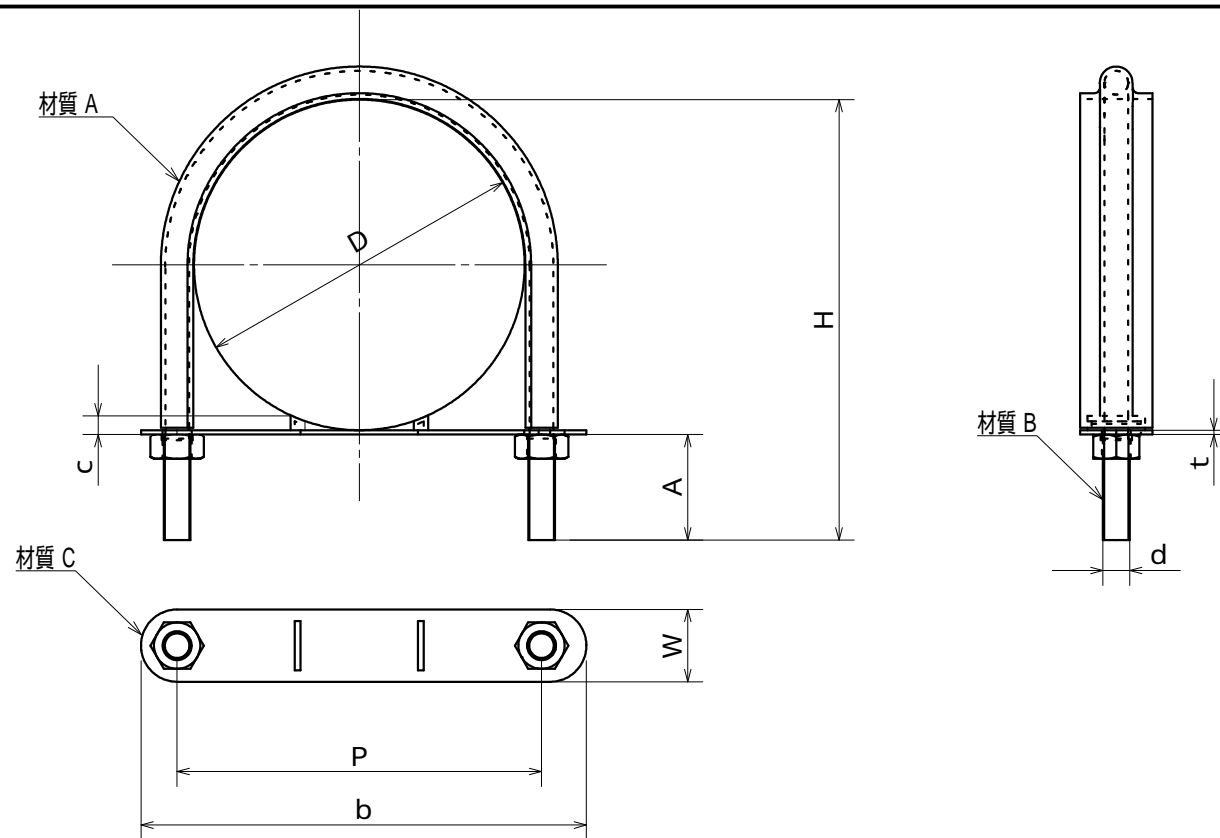

品番	サイズ	D	P	d	H	A	W	b	c	t
SU10343-0013	13SU	15.88	28	W3/8	46	23	25	53.5	7	1.5
SU10343-0020	20SU	22.22	34	W3/8	54	26	25	59.5	7	1.5
SU10343-0025	25SU	28.58	40	W3/8	60	26	25	66.5	7	1.5
SU10343-0030	30SU	34.0	46	W3/8	66	26	25	72.5	7	1.5
SU10343-0040	40SU	42.7	56	W3/8	75	25	25	83	7.5	1.5
SU10343-0050	50SU	48.7	62	W3/8	81	25	25	89	7.5	1.5
SU10343-0060	60SU	60.5	74	W3/8	93	25	25	101	7.5	1.5
SU10343-0075	75SU	76.3	88	W3/8	113	30	25	116	7.5	1.5
SU10343-0080	80SU	89.1	101	W3/8	126	30	25	129	8.5	1.5
SU10343-0100	100SU	114.3	126	W3/8	151	30	25	154	8.5	1.5
SU10343-0125	125SU	139.8	154	W1/2	187	40	30	190	9.8	1.8
SU10343-0150	150SU	165.2	182	W1/2	214	40	30	218	9.8	1.8
SU10343-0200	200SU	216.3	232	W1/2	264	40	30	268	9.8	1.8
SU10343-0250	250SU	267.4	286	W5/8	330	55	40	331	11	2.0
SU10343-0300	300SU	318.5	341	W5/8	391	65	40	386	11	2.0

品名 PRODUCT NAME		ステンレス SU管用 ELフラットUボルト 屋外用		サイズ SIZE	13SU ~ 300SU
品番 PARTS NO.	SU10343-	被覆色 COLOR	ブラック	表面処理 SURFACE TREATMENT	脱脂処理
材質 A MATERIAL A	エラストマー (TPE)	材質 B MATERIAL B	SUS304	材質 C MATERIAL C	エラストマー (TPE)
承認 APPROVAL	検図 CHECK	担当 IN CHARGE	A.Kaneshige	製図 DRAWN	21.02.15