

品番	サイズ	D	P	d	W	H	A
TP10359-0203	20+30	27.0	40	W3/8	25	79	50
TP10359-0253	25+30	32.0	46	W3/8	25	87	50
TP10359-0303	30+30	40.0	56	W3/8	25	96	50
TP10359-0403	40+30	50.0	62	W3/8	25	102	50
TP10359-0503	50+30	63.0	74	W3/8	25	113	50
TP10359-0653	65+30	75.0	88	W3/8	25	135	55
TP10359-0753	75+30	90.0	101	W3/8	25	145	55
TP10359-1003	100+30	125.0	137	W3/8	25	173	55
TP10359-1253	125+30	160.0	177	W1/2	30	224	65
TP10359-1503	150+30	180.0	195	W1/2	30	244	65
TP10359-2003	200+30	250.0	266	W1/2	30	314	65
TP10359-2503	250+30	315.0	341	W5/8	40	396	90

品名 PRODUCT NAME ドブメッキ TP管用 ELフラットUボルト 足長+30		サイズ SIZE 20~250	
品番 PARTS NO. TP10359-	被覆色 COLOR ブラック	表面処理 SURFACE TREATMENT 溶融亜鉛メッキ	
材質 A MATERIAL A エラストマー (TPE)	材質 B MATERIAL B SS400	材質 C MATERIAL C	
承認 APPROVAL	検図 CHECK	担当 IN CHARGE A.Kaneshige	製図 DRAWN 21.03.29

AWJ AWJ株式会社

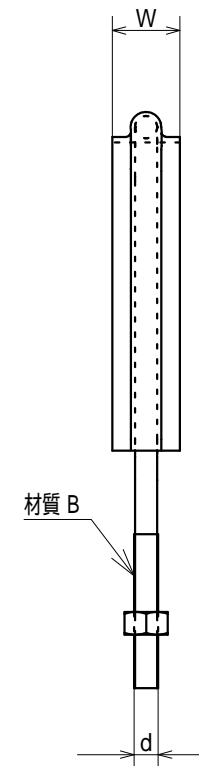
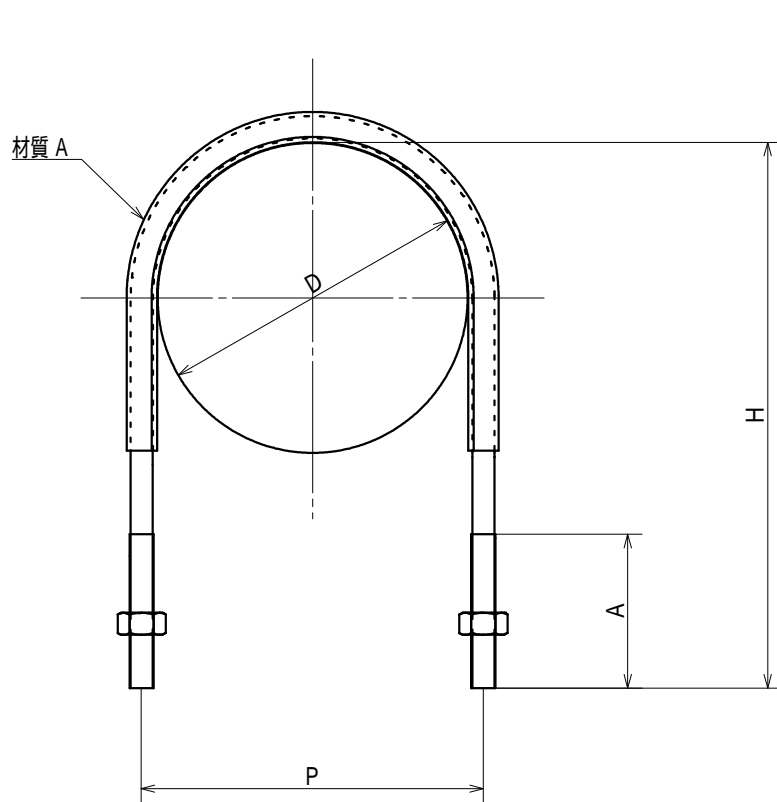

品番	サイズ	D	P	d	W	H	A
TP10359-0205	20+50	27.0	40	W3/8	25	99	66
TP10359-0255	25+50	32.0	46	W3/8	25	107	66
TP10359-0305	30+50	40.0	56	W3/8	25	116	66
TP10359-0405	40+50	50.0	62	W3/8	25	122	66
TP10359-0505	50+50	63.0	74	W3/8	25	133	66
TP10359-0655	65+50	75.0	88	W3/8	25	155	66
TP10359-0755	75+50	90.0	101	W3/8	25	165	66
TP10359-1005	100+50	125.0	137	W3/8	25	193	66
TP10359-1255	125+50	160.0	177	W1/2	30	244	65
TP10359-1505	150+50	180.0	195	W1/2	30	264	65
TP10359-2005	200+50	250.0	266	W1/2	30	334	65
TP10359-2505	250+50	315.0	341	W5/8	40	416	90

品名 PRODUCT NAME ドブメッキ TP管用 ELフラットUボルト 足長+50		サイズ SIZE 20~250	
品番 PARTS NO. TP10359-	被覆色 COLOR ブラック	表面処理 SURFACE TREATMENT 溶融亜鉛メッキ	
材質 A MATERIAL A エラストマー (TPE)	材質 B MATERIAL B SS400	材質 C MATERIAL C	
承認 APPROVAL	検図 CHECK	担当 IN CHARGE A.Kaneshige	製図 DRAWN 21.03.29

AWJ AWJ株式会社